

CHEETAH (YEAR 2000 onward.)

MOWER DECK - 1200mm

Complete Deck Assy 755200 (up to s/n 0602003)

755350 (1200 H/Duty Deck)

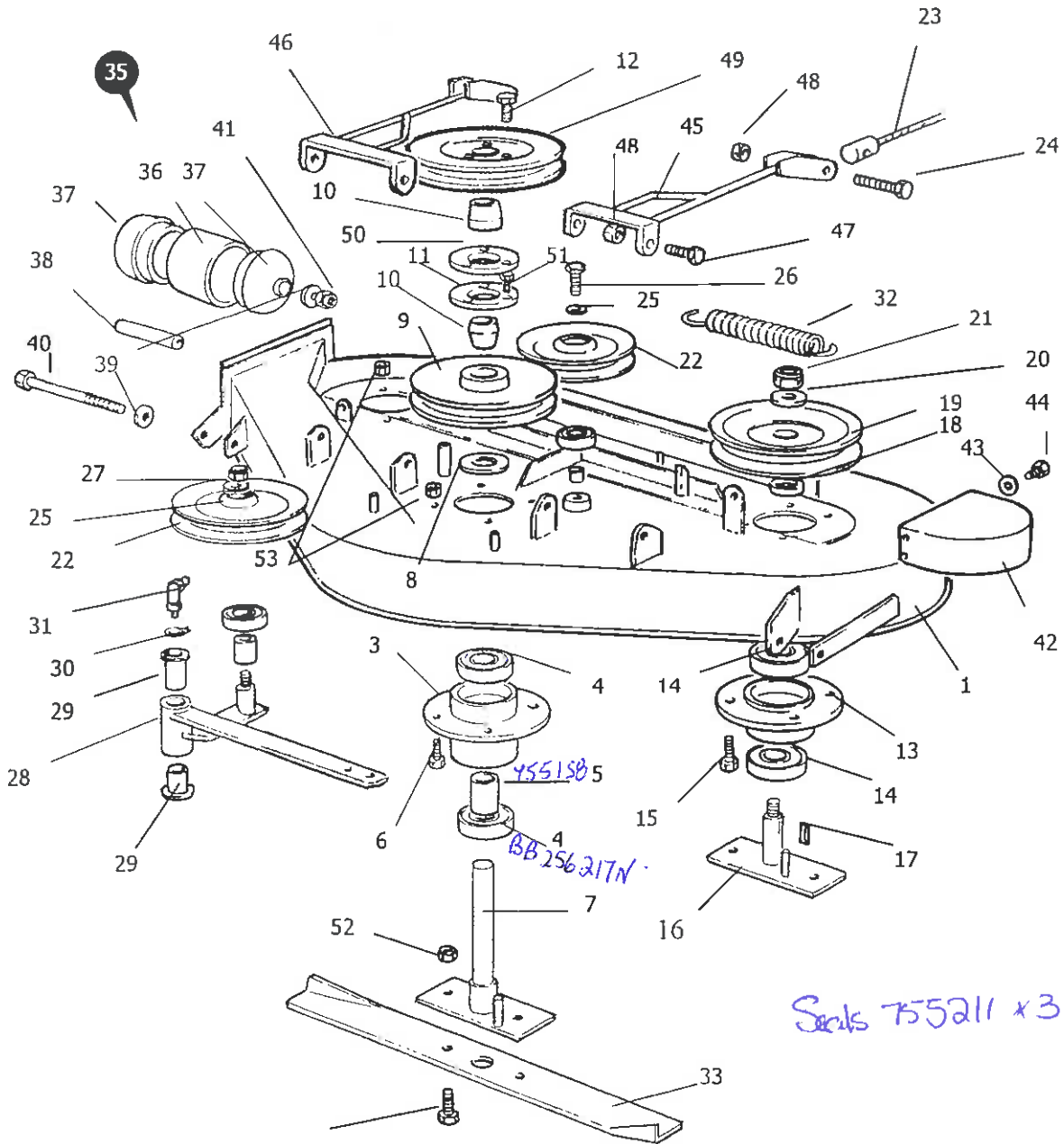

MOWER DECK – 1200mm

		1200 DECK P/N 755200 up to Serial No 0602003		18 hp		1200 H/DUTY DECK P/N 755350	
Item	Description	Qty	Part No	Qty	Part No	Qty	Part No
1	CHASSIS – 1200 Deck	1	755135	1	755135D	1	755251
2	BELT (not illustrated)	1	502103	1	502103	1	502103
3	HOUSING, Centre Spindle	1	755146	1	755146	1	755198
4	BEARING	2	BB256217N	2	BB256217N	2	BB256217
5	SPACER	1	755158	1	755158	1	755158
6	BOLT	4	750161	4	750161	4	750266
7	SPINDLE <i>Centre</i>	1	755136 <i>Non Naves</i>	1	755173	1 <i>Gr</i>	755248
8	WASHER, Spacer	1	850120	1	850120	1	755208
9	PULLEY	1	755138	1	755138	1	751205
10	COLLAR	1	750686	1	750686	4	750686
11	RETAINER, Drilled	1	751067	1	751067	3	751067
12	BOLT, 1/4" UNC X 1 3/4"	3	750108	3	750108	9	750108
13	HOUSING, Spindle	2	AM242	2	AM242	2	755198
14	BEARING	6	BB205215N	6	BB205215N		NA <i>BB256217</i>
15	BOLT	3	750161	3	750161	3	750266
16	SPINDLE <i>Outer</i>	2	755137	2	755172	2	755249
17	KEY, Pulley	2	755174	2	755174		NA
18	SPACER	2	755143	2	755143	2	755208
19	PULLEY	2	AM236	2	AM236	2	751205
20	WASHER, Flat	2	850151	2	850151		NA
21	NUT, Nyloc, M16	2	758153	2	758153		NA
22	PULLEY <i>Inner</i>	2	850117	2	850117	2	850117
23	ADJUSTER, Pan	2	750149	2	750149	2	750149
24	BOLT, M12 X 50	2	750124	2	750124	2	750124
25	WASHER	2	750153	2	750153	2	750153
26	BOLT	1	750161	1	750161	1	750161
27	NUT, Nyloc <i>3/8 x 1 1/4" Nut</i>	1	750135	1	750135	1	750135
28	ARM, Tension	1	755141	1	755141	1	755141
29	BUSH	2	750241	2	750241	2	750241
30	CIRCLIP, External	1	750207	1	750207	1	750207
31	GREASE NIPPLE	1	750216	1	750216	1	750216
32	SPRING, Tension	1	AM040	1	AM040	1	AM040
33	BLADE	3	755145	3	755145	3	755145
34	BOLT <i>3/8 x 1 1/4 bolt</i>	6	750161	6	750161	6	750161
35	ROLLER ASSEMBLY (Complete)	4	502285	4	502285	4	502285
36	TUBE, Roller	1	502095	1	502095	1	502095
37	CAP	2	502146	2	502146	2	502146
38	SHAFT	1	502164	1	502164	1	502164
39	WASHER, Flat	2	750153	2	750153	2	750153
40	BOLT, M10 X 120	1	502143	1	502143	1	502143
41	NUT, Nyloc, M10	1	750127	1	750127	1	750127
42	GUARD, Pulley	1	755142	1	755142	1	755142
43	WASHER, Flat	8	750160	8	750160	8	750160
44	BOLT, M6 X 16	8	750112	8	750112	8	750112
45	ARM, LH	1	755139	1	755139	1	755139
46	ARM, RH	1	755140	1	755140	1	755140
47	BOLT, M12 X 25	4	750140	4	750140	2	750140
Item	Description	Qty	Part No	Qty	Part No	Qty	Part No
49	PULLEY, Input	1	755148	1	755148	1	755148
50	RETAINER, Threaded	1	751068	1	751068	1	751068
51	BOLT 1/4" UNC X 1"	3	750110	3	750110	9	750110
52	NUT	6	750135 5	6	750135 5	6	750135 5
53	NUT	12	750135	12	750135	12	750127
54 Belt PTO (engine to deck)			755107		755107		755107

CHEETAH.
YEAR 2000 →

Current
1000 mm deck.

MOWER DECK - 1000mm

(PART 755201 - complete 13 hp)
PART 765202 - complete 1000 mm mulch deck
755450 complete 1000 mm heavy duty (14.5 hp)
76
18 hp

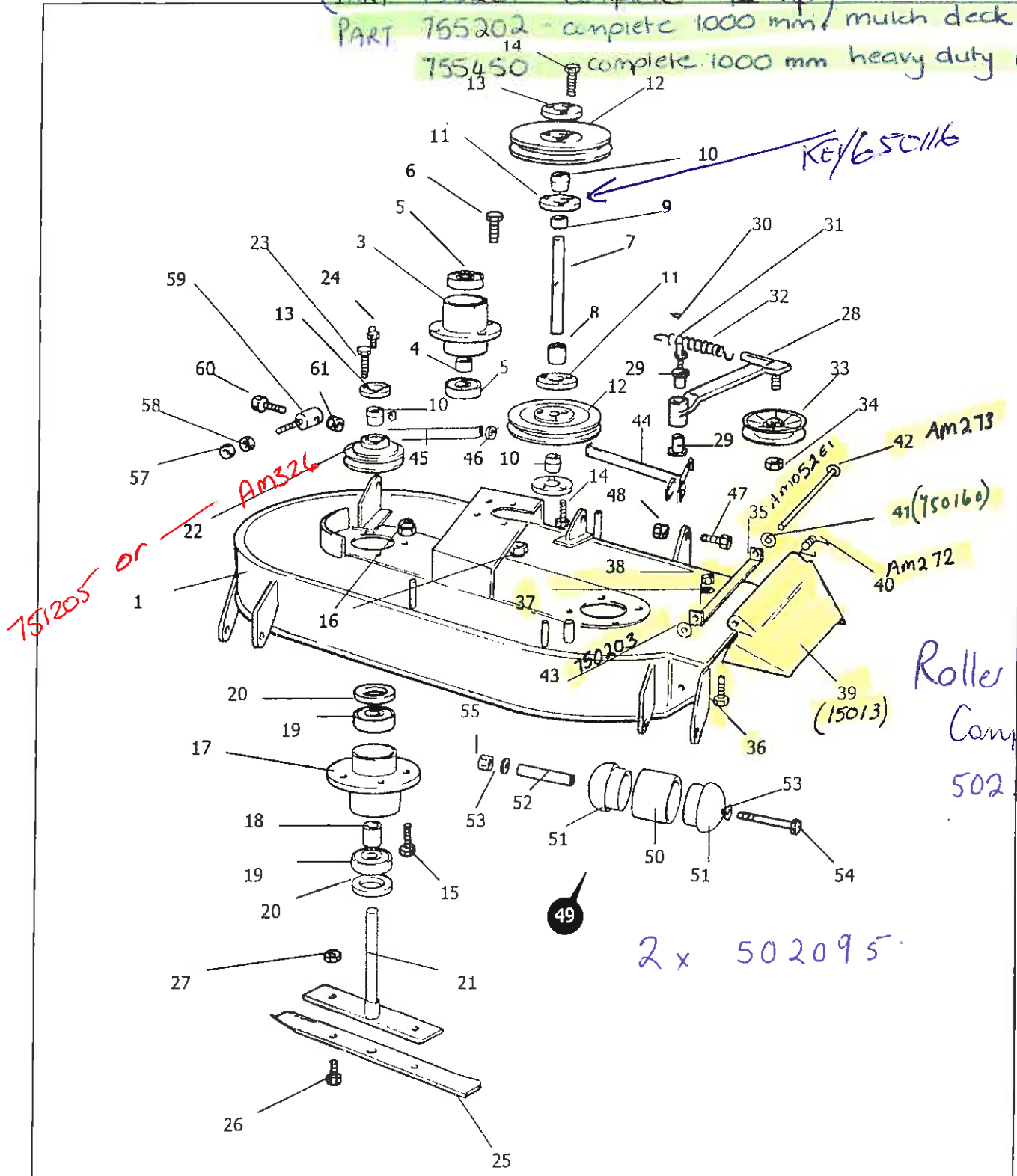

Roller Assy
Complete.
502285



MOWER DECK - 1000mm

			1000 Standard Deck P/N 755201		1000 Mulch Deck P/N 755202 ZT 1099		1000 Heavy Duty Deck P/N 755450
Item	Description	Qty	Part No	Qty	Part No	Qty	Part No
1	CHASSIS, 1000 Deck	1	755182	1	755451	1	755451
2	BELT (not illustrated) ZT 1099	1	500327	1	500327 13557	1	750401
3	HOUSING, Centre Spindle	1	AM242	1	AM242	1	AM242
4	SPACER, Bearing	1	755191	1	755191	1	755191
5	BEARING	2	750308	2	750308	2	750308
6	BOLT	4	750161	4	750161	4	750266
7	SHAFT	1	755188	1	755188	1	755188
8	SPACER, Bottom	1	755186	1	755186	1	755453
9	SPACER, Top	1	755187	1	755187	1	755187
10	COLLAR	2	750686	2	750686	4	750686
11	RETAINER, Threaded	2	751068	2	751068	2	751068
12	PULLEY	2	850137	2	850137	2	850137
13	RETAINER, Drilled	4	N/A		N/A	2	751067
14	BOLT, 1 3/4" X 1/4" UNC	6	750108	6	750108	6	750108
15	BOLT	8	750161	8	750161	8	750266
16	NUT, Nyloc	8	750135	8	750135	8	750127
17	HOUSING, Spindle	2	AM242	2	AM242	2	755198
18	SPACER	2	AM021	2	AM021	2	755158
19	BEARING	4	BB205215N	4	BB205215N	4	BB256217N
20	SEAL		N/A		N/A	4	755211
21	SPINDLE	2	755137 755269	2	755137 755269	2	755249
22	PULLEY	2	AM326	2	AM326	2	751205
23	HARDWARE, Pulley Retainer	1	758153	1	758153	6	750110
24	GREASE NIPPLE		N/A		N/A	2	750219
25	BLADE	2	755185	2	755382	2	755452
26	BOLT	4	750161	4	750161	4	750161
27	NUT, Nyloc	4	750135	4	750135	4	750135
28	ARM, Tension	1	755184	1	755184	1	755184
29	BUSH	2	750241	2	750241	2	750241
30	CIRCLIP, External	1	750207	1	750207	1	750207
31	GREASE NIPPLE	1	750216	1	750216	1	750216
32	SPRING, Tension	1	AM040	1	AM040	1	AM040
33	PULLEY ASSEMBLY	1	PIFBB02	1	PIFBB02	1	PIFBB02
34	NUT, Nyloc	1	750135	1	750135	1	750135
35	BRACKET	1	AM052E1	1	AM052E1	1	AM052E1
36	BOLT	2	750112	2	750112	2	750112
37	WASHER, Flat	2	750160	2	750160	2	750160
38	NUT, Nyloc	2	750101	2	750101	2	750101
39	DEFLECTOR	1	15013	1	15013	1	15013
40	SPRING	1	AM272	1	AM272	1	AM272
41	WASHER, Flat	1	750160	1	750160	1	750160
42	ROD	1	AM273	1	AM273	1	AM273
43	LOCKWASHER	1	750203	1	750203	1	750203
44	ARM, RH	1	755140	1	755140	1	755140
45	ARM, LH	1	755139	1	755139	1	755139
46	WASHER	1	750609	1	750609	1	750609
47	BOLT	2	750140	2	750140	2	750140
48	NUT, Nyloc	2	750104	2	750104	2	750104
49	ROLLER ASSEMBLY, Complete	4	502285	4	502285	4	502285
50	Tube, Roller	1	502095	1	502095	1	502095
51	Cap	2	502146	2	502146	2	502146
52	Shaft	1	502164	1	502164	1	502164
53	Washer, Flat	2	750153	2	750153	2	750153
54	Bolt, M10 X 120	1	502143	1	502143	1	502143
55	Nut, Nyloc, M10	1	750127	1	750127	1	750127
56	WASHER, Pulley	1	850151	1	850151		N/A
57	NUT, Nyloc	2	750128	2	750128	2	750128
58	NUT, Hex	2	750209	2	750209	2	750209
59	ADJUSTER, Pan	2	751049	2	751049	2	751049
60	BOLT	2	750124	2	750124	2	750124
61	NUT, Nyloc	2	750104	2	750104	2	750104

If gear model

= standard 755201

If hydro = heavy duty 755450

Deflector set up

Blade 20 H. 2 H. 1 H.

- ON MOWER h2 Pto Bolt 750278 750278 755102



56 Park Road
PO Box 185
Katikati

Phone: (07) 549 1237
Fax: (07) 549 0393
Email: kingcat@xtra.co.nz

Sales Office

Freephone: 0800 454 642
Phone/Fax: (09) 272 9109
Email: ~~bullmore@xtra.co.nz~~
Website: www.kiwimowers.co.nz

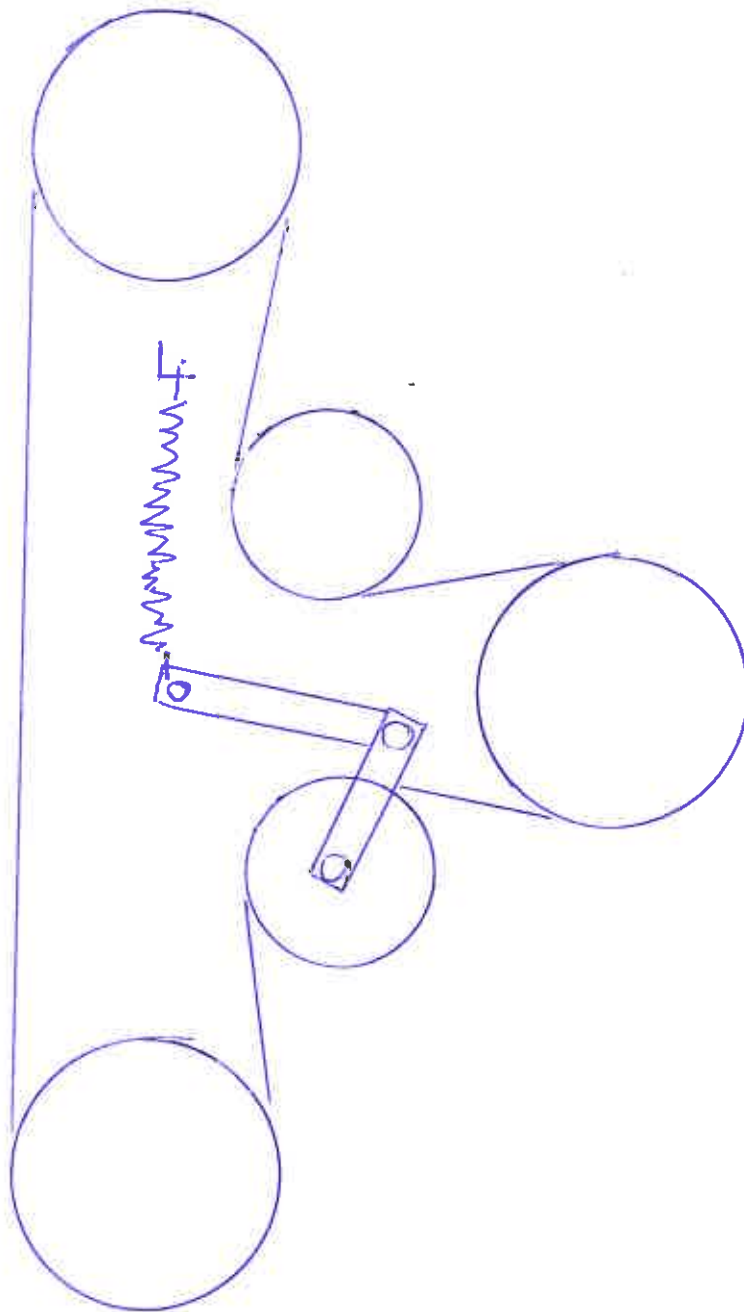

Belt Setup. Cheetah 1200 mm.
+ ZT 1200 Panther.